

# ENGINE POWERED FORKLIFT

# FGZN/FDZN 2.0 to 3.0 ton

## FGZN/FDZN SERIES



### THE SAME HIGH QUALITY AS ALWAYS

The FGZN/FDZN Series of engine-powered forklifts continues the tradition of high quality with reliable components.

#### Toyota-built Engine

High-power, energy-saving engine that is environment friendly



### OPERATOR-FRIENDLY DESIGN



#### Small-diameter Steering Wheel

The small-diameter steering wheel teams up with the full hydraulic power steering system to provide excellent maneuverability. The steering column offers stepless adjustment to accommodate a wide range of operator preferences.



#### Excellent Forward Visibility

The angled lower stay ensures a good view of the fork tips, which makes it easier to insert forks into the pallet on the ground.

### CONTINUATION OF SAFETY

#### Stable Design for the Vehicle Body

The use of a rear axle damper helps ensure lateral stability and supports safe operation.



#### Key-lift Interlock

When the key is switched off the forks do not descend even if the load-handling levers are operated. This can help prevent accidents caused by unintended operation by someone other than the operator.



#### Lattice-design Headguard

The headguard uses a lattice design that combines outstanding upward visibility and strength.

### FRIENDLY TO THE OPERATING ENVIRONMENT

#### Low-noise and Low-vibration Design

The Toyota-built engine and the floating design for the engine mounting achieve low levels of noise and vibration.

#### Easy-down System

When the forks are lowered, this system controls the speed of descent before the forks touch the ground, dramatically reducing the noise of landing.

Note: Installed only on the V Mast



### EASY MAINTENANCE

#### Engine Hood

The wide-opening engine hood offers easy access to the engine compartment for inspection or servicing.

### ENVIRONMENTAL PROTECTION

Continuing Toyota's environmental-conservation concepts, the FGZN/FDZN series uses lead-free paint and plating free of hexavalent chromium, thereby contributing to the reduction of environmental impact and protection of the global environment.



Hexavalent  
Chromium-Free



Lead-Free

## MAIN SPECIFICATIONS

Model		FGZN20	FDZN20	FGZN25	FDZN25	FGZN30	FDZN30
Engine Model		4Y Gasoline	1DZ-III Diesel	4Y Gasoline	1DZ-III Diesel	4Y Gasoline	1DZ-III Diesel
Transmission	Type	Powershift		Powershift		Powershift	
Load Capacity	kg	2000		2500		3000	
Load Center	mm	500		500		500	
Overall Width	A	1150		1150		1255	
Turning Radius (outside) B	mm	2200		2260		2400	
Overhead Guard Height C	mm	2130		2130		2195	
Length to Fork Face	D	2570		2650		2770	

## ENGINE SPECIFICATIONS

Model		TOYOTA 4Y Gasoline	TOYOTA 1DZ- III Diesel
Piston Displacement	cc	2237	2486
Rated Power/r.p.m.	kW/rpm	30/2000	33/2200
Rated Torque/r.p.m.	N-m/rpm	153/1600	148/2100

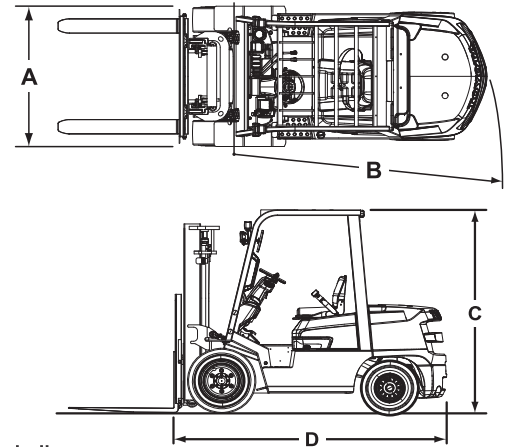

### HEAD OFFICE

**Toyota Material Handling India Pvt. Ltd.**  
 43 Mile Stone, NH-8, Delhi - Jaipur Highway, Gurugram - 122004, Haryana, India  
 Ph.: +91-0124 - 3877100  
 E-mail: info.sales@tmhin.toyota-industries.com, Web:www.toyotamaterialhandlingindia.com

### BRANCH OFFICES

- Delhi:** 43 Milestone, NH-8, Delhi-Jaipur Highway, Gurugram – 122004, Haryana  
 M: +91-9810997357 , T: +91 124 3877102
- Punjab:** Motiaz Royal Business Park, Office No. 05, First Floor, Chandigarh-Ambala, Highway, Royal Motia City Road, Village – Singhpura, Sub Tehsil - Zirakpur -140603, Punjab  
 M: +91-8600011280
- Kolkata:** ASO – 628 6th Floor, Astra Towers 2C/1 Action Area II C, Rajarhat, Kolkata – 700161, West Bengal  
 M: +91-9717725926
- Pune:** GAT NO. 869, Tal - Khed Pune, Nighoje village, Pune- 410501, Maharashtra,  
 M: +91-7738694001
- Ahmedabad:** A-609 Privilon, Iskon Ambli Cross Road, B/H Iscon Temple, S.G Highway Ahmedabad-380051, Gujarat  
 M: +91-8600239978
- Mumbai:** 1203, 12th Floor, The Affairs Building, Palm Beach Road, Sector - 17, Sanpada, Navi Mumbai – 400705, Maharashtra  
 M: +91-9004415045
- Bangalore:** Plot No. 66-J&K, Sector-2, Bidadi Industrial Area, 2nd Phase, Shyanumangala, Bidadi Hobli, Ramanagara Taluk & District-562109, Karnataka  
 M: +91-9845003971
- Hyderabad:** #605, Shangrilla Plaza, Road No.2, Banjara Hills, Hyderabad – 500034, Telangana  
 M: +91-9741426287
- Chennai:** Krishna Tower, 1st Floor, 31-B, North Phase Thiru-VI-KA Industrial Estate, Ekkattuthangal, Chennai-600032, Tamil Nadu  
 M: +91-9600986222
- Coimbatore:** C/o Ganapathy Rest Home, 1st Floor, Above Indian Overseas Bank, No. 1, Sanganoor Road, Ganapathy Pudur, (Near Kannan Departmental Stores), Coimbatore – 641006, Tamil Nadu  
 M: +91-9600954666