

Hand pallet truck 1.0 ton

BT lifter

L-series

LHM100ULF



Hand pallet truck

Truck specifications					LHM100ULF	LHM100ULF	LHM100ULF
Identification	1.1	Manufacturer			BT	BT	BT
	1.2	Manufacturer's type designation			LHM100ULF	LHM100ULF	LHM100ULF
		Fork length		mm	800	1150	2000
	1.4	Operator type			Hand	Hand	Hand
	1.5	Load capacity/rated load	Q(t)	kg	1000	1000	1000
	1.6	Load centre distance	c	mm	400	600	1000
	1.8	Load distance, centre of drive axle to fork	x	mm	530 ¹⁾	880 ¹⁾	1730 ¹⁾
	1.9	Wheelbase	y	mm	780 ¹⁾	1130 ¹⁾	1980 ¹⁾
Weight	2.1	Service weight		kg	79	95	116
Wheels	3.1	Steer/fork/support wheels: Steel (S) Nylon (N), Polyurethane (P)			N / P, S / N	N / P, S / N	N / P, S / N
	3.2	Wheel size, front			175x60	175x60	175x60
	3.3	Wheel size, rear			38x76 ²⁾	38x76 ²⁾	38x76 ²⁾
	3.5	Wheels, number front/rear (x=driven wheels)			2/4	2/4	2/4
	3.6	Track width, front	b ₁₀	mm	132	132	132
	3.7	Track width, rear	b ₁₁	mm	364	364	364
Dimensions	4.4	Lift	h ₃	mm	100	100	100
		Lift height	h ₂₃	mm	138	138	138
	4.9	Height of tiller in drive position, min./max.	h ₁₄	mm	1220	1220	1220
	4.15	Height, lowered	h ₁₃	mm	38	38	38
	4.19	Overall length	l ₁	mm	1165	1515	2365
	4.20	Length to face of forks	l ₂	mm	365	365	365
	4.21	Overall width	b ₁	mm	685	685	685
	4.22	Fork dimensions	s/e/l	mm	38/280/800	38/280/1150	38/280/2000
	4.25	Width over forks	b ₅	mm	280	280	280
	4.32	Ground clearance, centre of wheelbase	m ₂	mm	5	5	5
	4.33	Aisle width for pallets 1000 x 1200 crossways	A _{st}	mm	—	1595 ¹⁾	—
	4.34	Aisle width for pallets 800 x 1200 lengthways	A _{st}	mm	—	1795 ¹⁾	—
4.35	Turning radius	W _a	mm	1025 ¹⁾	1375 ¹⁾	2225 ¹⁾	
Others	5.3	Lowering speed, with/without load		m/s	Controlable	Controlable	Controlable
		Outside width of steel arm for support wheels		mm	685	685	685
		Pump unit					

1) Distance with forks raised to centre of first boggie wheel.

2) Boggie wheel.

All data are based on table configuration. Other configurations may give other values.

Truck performance and dimensions are nominal and subject to tolerances.

Specifications are subject to change without notice.

Dimensional drawings

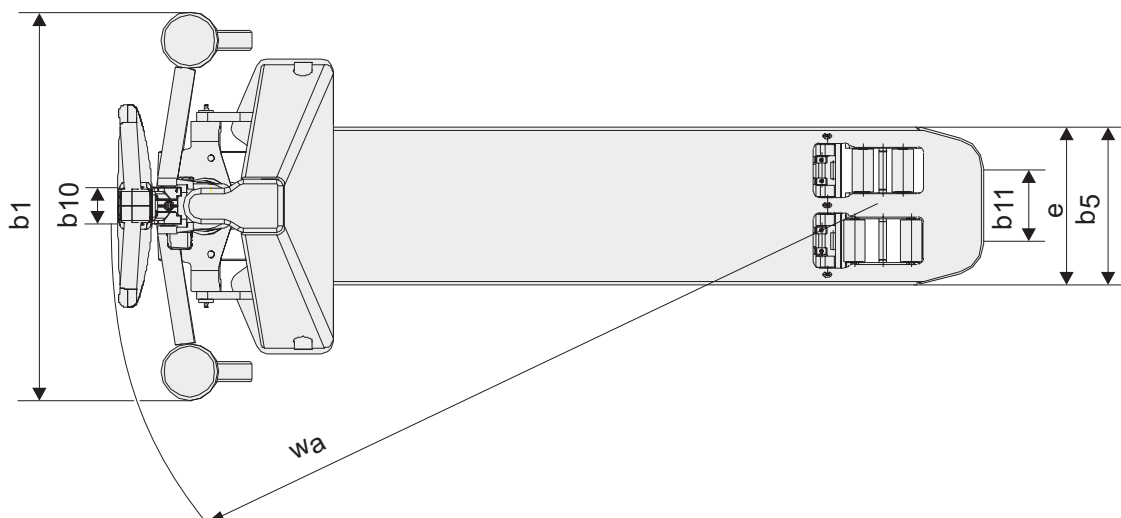
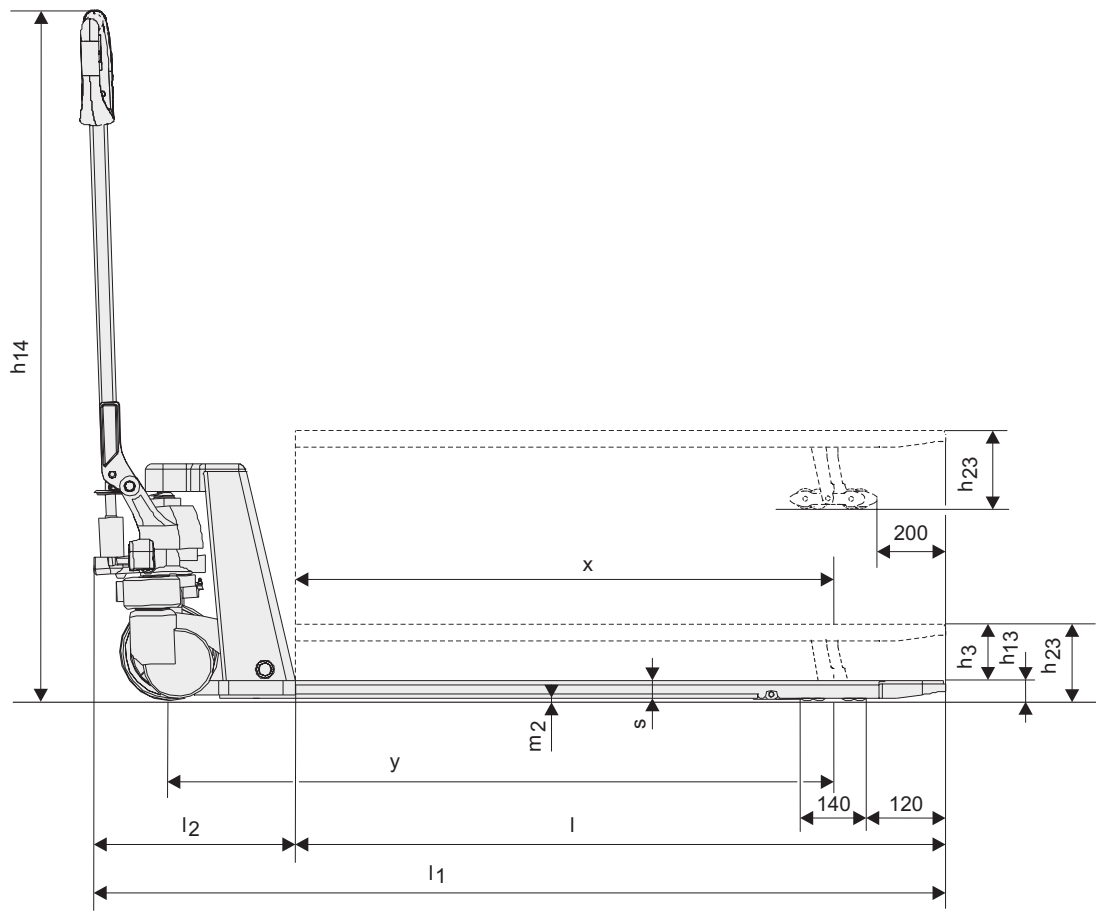

Truck features:

- Designed for load carriers with very low pallet tunnel.
- Quick Lift function is standard.
- Customized configurations – a part of our offer.
- Robust design and still low weight – easy to manoeuvre.
- Powder coating for durable finish.
- Angled high strength polymer handle for best ergonomic grip.
- BT lowering control valve enables smooth, controlled lowering action.
- Strong powerful thrust bearing is standard, for easier steering and enhanced durability
- Greasable bushings ensure long service life.
- Quick lift and overload valve are combined.



TP-Technical Publications, Sweden — 745352-040, version 3, 1305